

Street Fighter

STREETFIGHTER PERFORMANCE AIRBOX 2018-2020 CAMARO 2SS

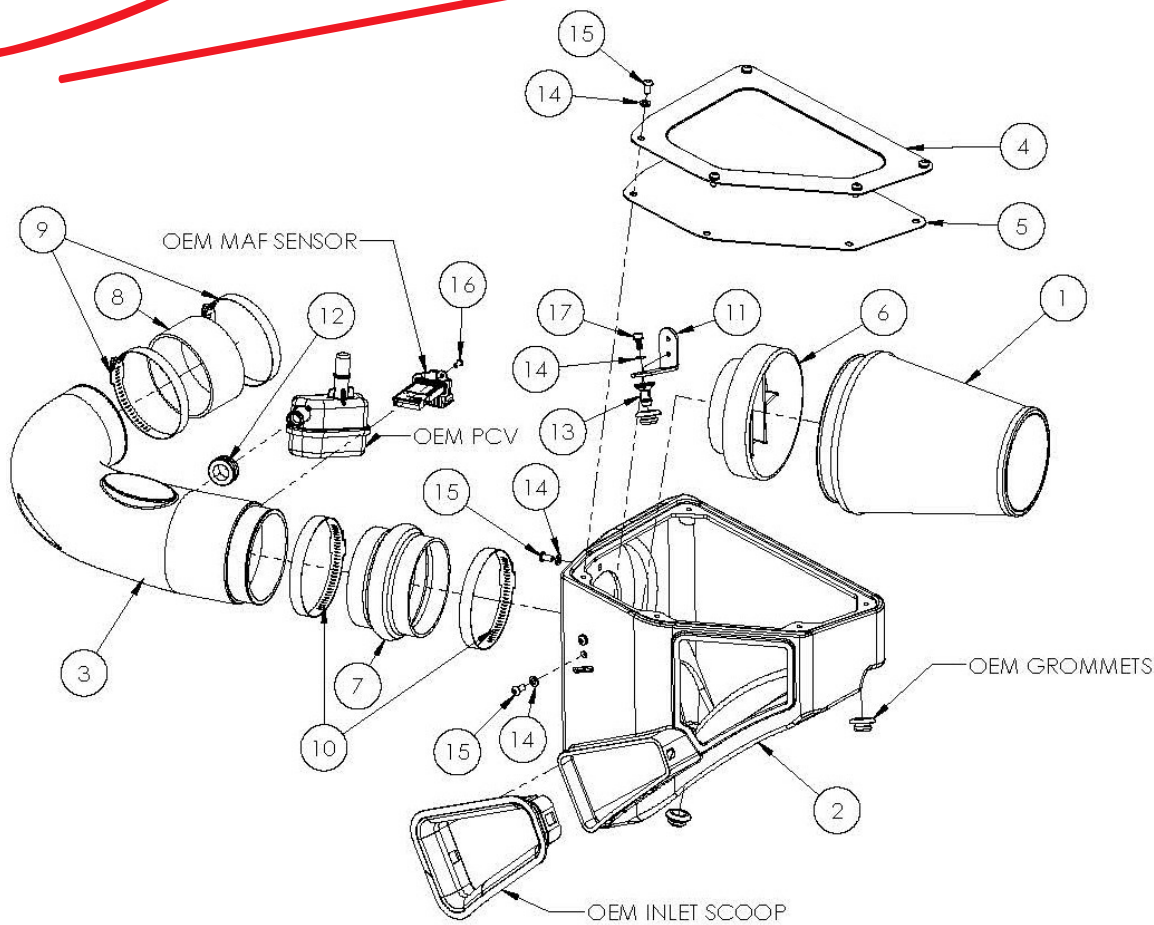

Component Identification

1	700/701-461	Power Filter	1
2	KIT333CAB	StreetFighter Intake Airbox	1
3	KIT333	StreetFighter Intake Tube	1
4	KIT333LID	StreetFighter Airbox Lid	1
5	KIT333G	Airbox Lid Gasket	1
6	KITMAFADA01	Filter Adapter	1
7	KITHUMPHS05EPDM	Hump Hose	1
8	KITCOUPLER10EPDM	Coupler	1
9	08624	#60 Hose Clamp	2
10	KITHS72	#72 Hose Clamp	2
11	KIT333BC	Airbox Bracket	1
12	KITGRMT19	Grommet	1
13	8-186	Airbox Mounting Post	1
14	1-3016	Flat Washer	11
15	KIT15DHC3050	1/4-20 Button Head Screw	10
16	KIT15BHC3050	#8-32 Button Head Screw	2
17	KIT60C120HCS	6mm Hex Bolt	1
			1
			1



1. Inside the trunk, on the passenger side, locate and remove the battery access panel. Disconnect the Negative battery terminal.

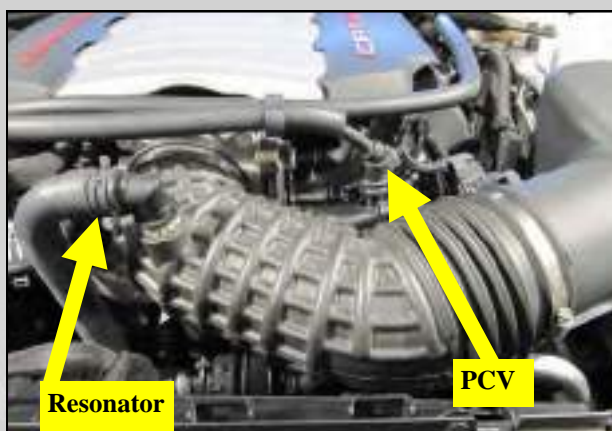

2. Compress the spring clamp on the resonator tube and separate the tube from the 90 deg. fitting in the intake tube. Depress the grey locking tab in the PCV fitting and disconnect the PCV line from the intake.



3. Loosen the clamps on both ends of the intake tube and remove it from the vehicle.



4. Disconnect the air flow meter, or MAF, in the air box lid and remove the entire airbox assembly from the vehicle.

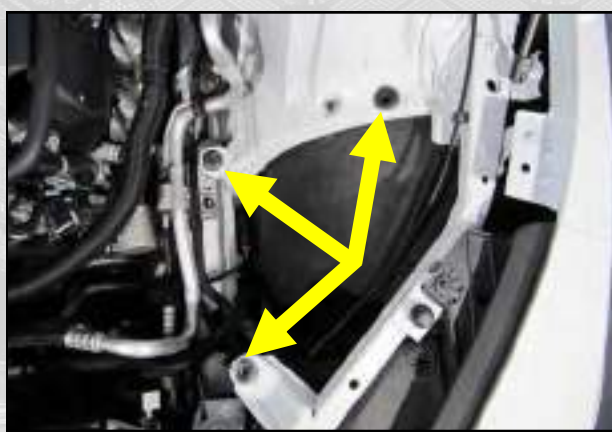

5. Ensure that all 3 airbox mounting grommets remain in the vehicle.



6. Remove the two bolts in the resonator diaphragm bracket using a T-50 Torx bit or with a pair of locking pliers as shown. The resonator, bolts and bracket will not be used with the StreetFighter Performance Airbox.



7. Locate the upper half of the resonator tube near the master cylinder and disconnect the tube retainers on the strut tower brace and the A/C line.



8. At the firewall, remove the 6mm flange nut at the resonator tube base. Turn the tube 1/4 turn Clockwise and remove it from the vehicle.



9. Insert the Firewall Plug into the resonator tube hole.

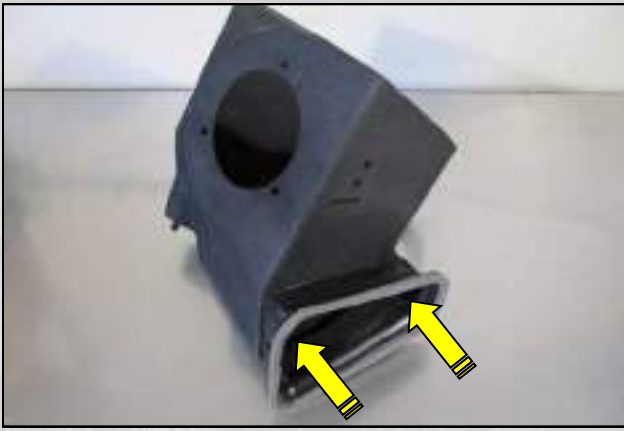

10. Transfer the factory air box inlet onto the airbox as shown.

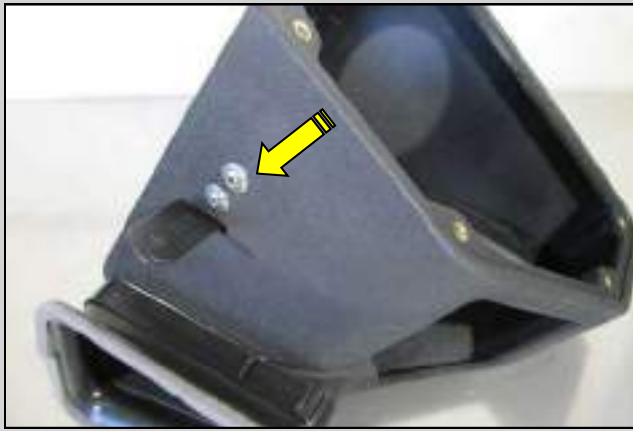

11. Slide the Airbox Bracket into the slot above the air inlet, from inside the box, and secure it using two sets of 1/4-20 Button Head Screws and Flat Washers.

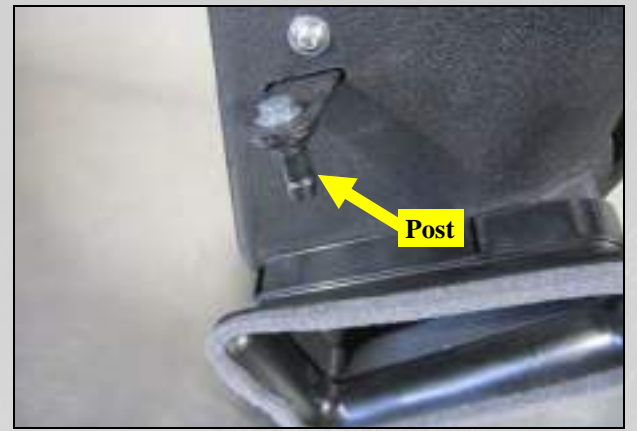

12. Install the Airbox Mounting Post onto the Bracket, as shown using the 6mm Hex Bolt and one Flat Washer.

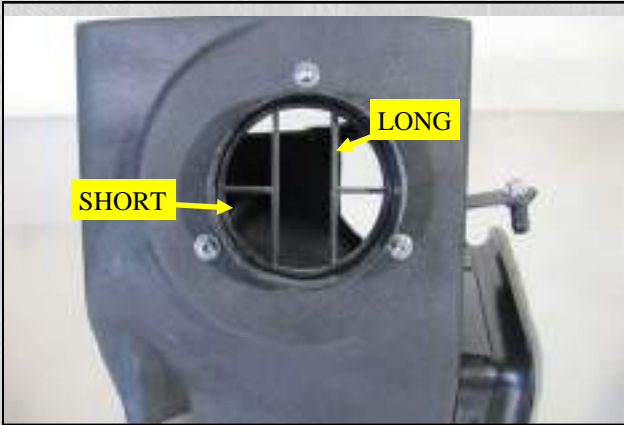

13. Install the Filter Adapter onto the Airbox using three sets of 1/4-20 Button Head Screws and Flat Washers. Note the positioning of the Adapter in the Airbox. When properly installed, the long air vanes are vertical and the short vanes are horizontal.



14. Transfer the MAF Sensor from the factory airbox, into the Intake Tube and secure it using the supplied #8 Button Head Screws. Insert the Grommet into the Intake Tube as shown.

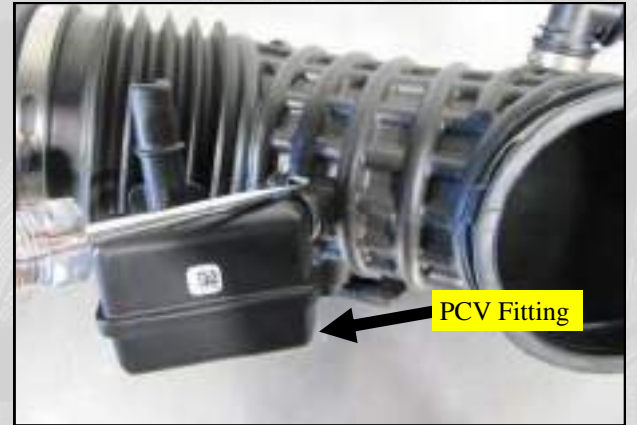

15. Using a small flat tip screwdriver, uncrimp the clamp securing the PCV fitting to the intake tube.



16. Transfer the PCV fitting into the Grommet in the StreetFighter Performance Airbox Intake Tube.



17. Place the Airbox assembly into the engine compartment as shown, with the mounting posts only fully seated in all three grommets.

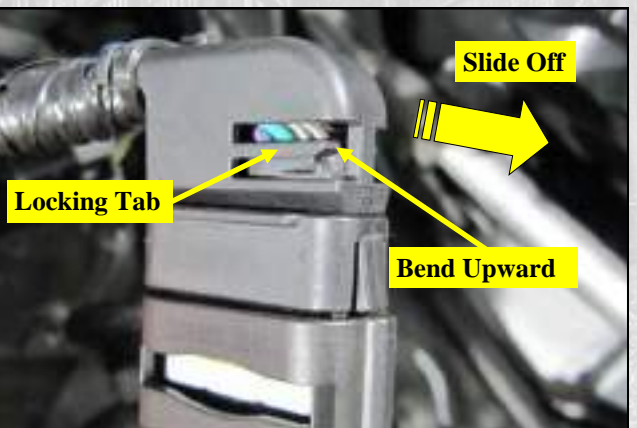

18. The connector for the MAF sensor has a 90 degree wire guide on it. Cut the zip tie on the guide. Locate the locking tabs on both sides of the guide and bend the tabs upward to slide the guide off of the connector. This will not be used with the StreetFighter Performance Intake.

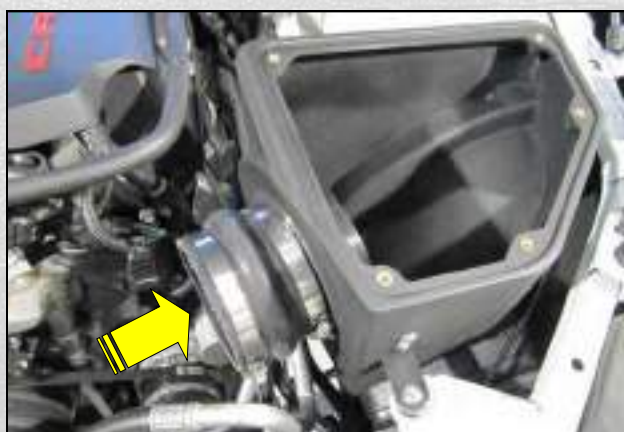

19. Slide the Hump Hose and # 72 Clamps onto the Filter Adapter.



20. Slide the Coupler and #60 Clamps onto the throttle body as shown.

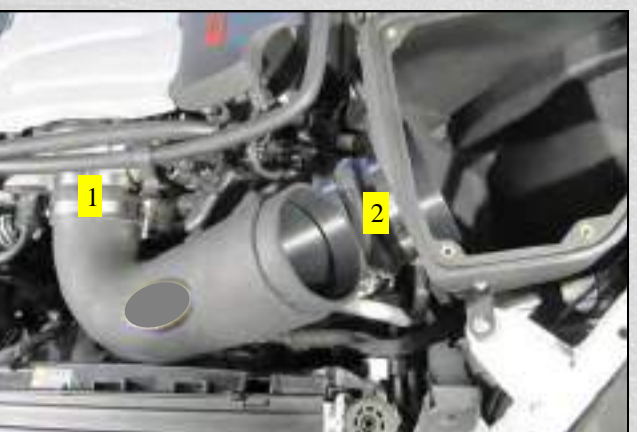

21. Insert the Intake Tube into the Coupler first, then into the Hump Hose.



22. Align the Intake Tube and tighten all four Clamps.



23. Install the StreetFighter Premium Airfilter on to the Fitted Adapter in the Airbox.



24. Remove the protective film from the Polycarbonate Lid and mount it to the Airbox using 5 sets of 1/4-20 Button Heads and Flat Washers along with the StreetFighter Anodised Cover.

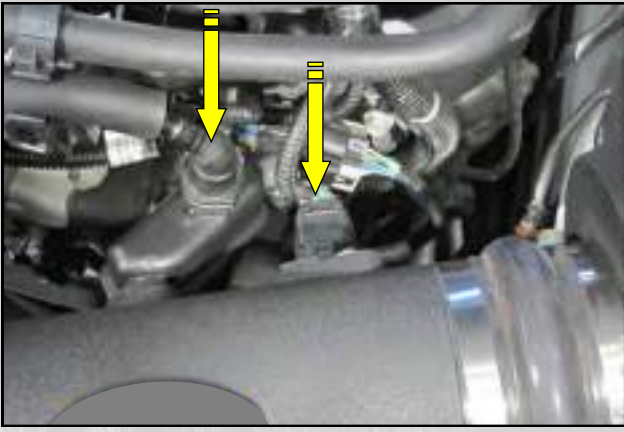

25. Reconnect the PCV line and the MAF.



26. Slowly lower the hood to test clearances. Make sure all clamps, hoses, bolts, and screws are tight. Double check the hood clearance. Reconnect the negative battery terminal and re install the access panel.

FILTER DOES NOT REQUIRE OIL. SERVICE FILTER AS REQUIRED BY CLEANING WITH NON-PETROLEUM BASED ALL PURPOSE HOUSEHOLD CLEANER AND WATER. APPLY CLEANER TO OUTSIDE OF AIR FILTER AND ALLOW TO SOAK. ONCE SOAKED, FLUSH FILTER FROM INSIDE OUT WITH GARDEN HOSE AND REPEAT IF NECESSARY. DO NOT APPLY HIGH PRESSURE WATER OR AIR TO CLEAN FILTER. ALLOW TO DRY THEN REINSTALL.



Street Fighter

WWW.STREETFIGHTER.NET.AU